



NORTHERN WOMEN'S
— **RODEO ASSOCIATION** —

2024

**ARTICLES, BYLAWS
AND
OFFICIAL RODEO RULES**

TABLE OF CONTENTS

Articles of Incorporation	3
Bylaws	7
Membership.....	7
General Rules	7
Membership Categories.....	14
Meeting of Members	16
Officers and Board of Directors	17
Rulechanges	21
Indemnification.....	21
Rodeo Approval.....	22/23
Rodeo Administration	22/26
Central Entry	28
Secretary and Rodeo Office.....	30
Point Awards and Payoff	34
Trade Outs, Turn Outs	37
Disciplinary Action	38
Disciplinary Procedures	43
Grievance Procedure	44
Humane Treatment of Livestock	46
Judging Program	48

TABLE OF CONTENTS (CONT'D)

Complaints Against Judges	48
Rules of Competition	50
Arena Rules	50
Timed Event Rules	53
Barriers and Scoreline	53
Barrier.....	56
Drawing Timed Event Stock	59
Ladies Breakaway Roping Rules	62
Ladies Cloverleaf Barrel Racing Rules	63
Method for Marking Barrels	67
Electronic Eye Timer.....	69
Annual N.W.R.A. Finals Qualifications	70
Finals Personnel and Stock	70
Payoff	71
Time Limits	71
Entry Closing.....	72

**ARTICLES OF INCORPORATION
OF THE
NORTHERN WOMEN'S RODEO ASSOCIATION**

This is to certify that we, the undersigned, do hereby associate ourselves into a Corporation under and by virtue of the Montana Non-Profit Corporation Act and the Laws of the State of Montana, and to that end do hereby set forth:

ARTICLE 1. The name of the Association shall be NORTHERN WOMEN'S RODEO ASSOCIATION.

ARTICLE 2. The Association shall have perpetual existence.

ARTICLE 3. The objects and purpose for which the Association is formed are as follows:

To establish and perfect an association not for profit interested in the promotion of women's rodeo events, including but not limited to barrel racing and breakaway roping.

To elevate the requirements and standards of Women's rodeo and organize female contestant for their mutual protection benefit.

To develop within contestants a spirit of fair competition and appreciation of good sportsmanship

To safeguard the interests of sponsoring agencies, and to protect the health and welfare of contestants in competition.

To encourage and promote rodeos

within approved standards, rules and requirements.

To protect the interests of contestants in the matter of advertised rodeo prize lists for which they compete.

To do any other lawful act concerning any and all lawful business for which corporations may be organized under Title 35, Chapter 2, of the Non-Profit Corporation Act.

ARTICLE 4. The Association in a non-profit, charitable and educational corporation and has no capital stock. Conditions for membership are as follows:

Members shall include such persons, firms and corporations as shall meet the terms and conditions for membership as prescribed from time to time by the By-Laws of the Association. No dividends will be paid, and no part of the net earnings of the Association will be distributed to any director, officer, or member of the Association.

ARTICLE 5. The number of directors of the Association in which they shall be elected shall be provided for and determined by the By-Laws of the Association.

ARTICLE 6. The address of the initial registered office of the Association is: PAYS Building, 112 South 18th, Billings, MT. 59101.

The registered office of the Association may be, but need not be, identical with the principle office above stated, and the address of the registered office may be changed from time to time by the Board

of Directors, upon proper notice to the Montana Secretary of State. The name of the initial registered agent at such address is Theresa Caldwell.

ARTICLE 7. The number of directors constituting the initial Board Directors shall be eight (8).

ARTICLE 8. The names and addresses of the Members of the initial Board of Directors are as follows: President: Chris McQueary, 5300 Burnt Road, Belgrade, MT. 59714; Vice President: Mary Goyins, 910 Sierra Road West, Helena, MT. 59602; Director at Large: Nancy Petersen, Box 28, Three Forks, MT. 59752; Ladies Barrel Racing Director: Paula Harris, 2009 Highway 87 East, Billings, MT. 59101; Ladies Breakaway Roping Director: Rhonda Kountz, 8612 Huffine Lane, Bozeman, MT. 59718; Advisory Board Member: Marcey Chaffee, 3902 North Tanager Lane, Billings, MT. 59102; Advisory Board Member: Mary Salmond, HC 58 Box 38, Choteau, MT. 59422; Advisory Board Member: Kris Bartholomew, Box 2384, Colstrip, MT. 59323. The Incorporator of the Association Theresa Caldwell, PAYS Building 112 South 18th, Billings, MT. 59101.

ARTICLE 9. In order to properly prosecute the objects and purposes hereinabove set forth, the Association shall have full power to receive donations, requests and devises; to purchase, lease and otherwise acquire and hold; to sell, donate and otherwise dispose of all kinds of property to donate all or any part of equipment, materials or facilities incidental to any such program or activities; and generally to do any and all acts and things which may be deemed necessary or expedient for the development, expansion and

extension of Women's rodeo events and programs in genera.

ARTICLE 10. The management of the Association and its properties shall be vested in a Board of Directors which shall have full power and authority from time to time without the assent or vote of the members to sell, donate or otherwise dispose of any and all of the property of the Association in furtherance of any of the objects and purposes for which the Association is formed.

ARTICLE 11. No Director of the Association shall receive any compensation what-so-ever for his or her services as such Director or Officer of the Association.

ARTICLE 12. Notwithstanding, any other provision of these Article, the Association shall not carry on other activities not permitted to be carried on:

by a corporation exempt from federal income tax under section 501(c)(3) of the Internal Revenue Code and its regulations as they may not exist or as they may hereafter be amended; or,

by a corporation, contributions to which are deductible under Section (170)(c)(2) of the Internal Revenue Code and its regulations as they now exist or as they may hereafter be amended.

ARTICLE 13. Upon the dissolution of the Association, the Board of Directors shall, after paying or making provision for the payment of all the debts of the Association shall, distribute the assets of the Association exclusively for the purposes of the Association in such manner or to such organization or

organizations under Section 501(c)(3) of the Internal Revenue Code and its regulations as they now exist or may hereafter be amended, as the Board of Trustees shall determine.

**BYLAWS OF
THE
NORTHERN WOMEN'S RODEO ASSOCIATION
(NWRA)**

The principal office of the Association shall be located at the Public Auction Yards, 18th and Minnesota Avenue, Billings, Montana, 59101. Such principal office may be moved from time to time by majority vote of the Directors.

Any bylaw may be amended upon the following conditions: that the Board of Directors shall be notified of meeting to be held for the purpose of amending bylaws, and that the majority of such meeting of Board of Directors be in favor of such amendments, providing that there is a quorum of the Board of Directors. Complete authority for amending or revising the bylaws shall be within the power of the Board of Directors.

SECTION 1 - MEMBERSHIP

M.1.0 GENERAL RULES:

M.1.1 Membership is limited to women only. Membership shall be a privilege and not a right. Only persons born female by evidence of a valid birth certificate shall be eligible for membership.

M.1.2 All rodeo secretaries, timers and contestants must be members of the Association.

M.1.3 A female contestant who otherwise meets the qualification for membership may compete at one hometown rodeo without joining the Association

if proof of residence of reasonable proximity is accepted by the rodeo secretary or rodeo committee. Reasonable proximity will be determined in each instance by each rodeo committee.

M.1.3.1 All local entries will be taken through Central Entry. Local entry contestant must give Central Entry a current address that is within the local entry area. Local entry contestant must sign a local release form and pay entry fees to rodeo secretary before they compete, or they will be assessed a \$100.00 fine plus fees. All local entry winnings will be mailed from the NRA Office when sufficient proof of residency is received. The NRA will accept the following as proof of residency: drivers license, voter ID card, utility bill or bank statement. Proof of residency must be received no later than 10 days after the last performance. If proof of residency is not received the contestant is not eligible for payoff. Contestant entry fees will remain in the payoff and payoff will be refigured and paid out accordingly.

M.1.4 Any person becoming a member of the NWRA shall become familiar with its Rules and Bylaws and shall comply and be bound by same. Only members in good standing shall be eligible to participate in all activities of the NWRA and shall be eligible to receive any awards or benefits sanctioned by the Rules of the NWRA.

M.1.5 The Board of Directors and administration of the NWRA will expect the cooperation of any member when called upon by one of the NWRA or Northern Rodeo Association (NRA) officials to represent the NWRA's and NRA's interest regarding enforcement of Rules at any approved

rodeo or in any matter of official business. Should an occasion arise requiring representation at a rodeo, any member in good standing may call the NWRA office for instructions if no director or representative is present.

M.1.6 Northern Women's Rodeo Association members and permit holders acknowledge that rodeos generally are dangerous activities by their inherent nature and that participation in a rodeo as a competitor, laborer, official, observer or volunteer in areas to which access to the general public is restricted (including, without limitation, the competition area, chutes, rodeo arena, pens and other areas reserved and intended for use or access by the rodeo participants or otherwise restricted to the general public) exposes the participant to substantial and serious hazards and risks of property damage, personal injury and/or death. NWRA members and permit holders acknowledge that their participation in NWRA sanctioned rodeos likewise involves such hazards and risks. Being fully aware that participation in a NWRA sanctioned rodeo will result in exposure to substantial and serious hazards and risks of property damage, personal injury and/or death, each NWRA member or permit holder, in consideration of being permitted to participate in the NWRA sanctioned rodeo in any capacity, does by such participation agree to assume such hazards and risks, and does thereby discharge, waive, and release the NWRA and NRA sponsors, all NWRA and NRA members, (including, without limitation, contestants, stock contractors, rodeo producers and contract personnel), any NWRA and NRA rodeo committee, and any other NWRA sanctioned

rodeo production entity involved in the sanctioning, production, organization, conduct, sponsoring and/or performance of the subject rodeo (and such persons or entities affiliated, related or subsidiary companies and their respective officers, directors, employees and agents) from all claims, demands and liabilities for any and all property damage, personal injury and/or death or other responsibility arising from such member's or permit holder's participation in an NWRA sanctioned rodeo, including claims, demands, liabilities, and other responsibility that are known or unknown, foreseen or unforeseen, future or contingent, and whether or not such claims, demands, liabilities, and other responsibility is occasioned by the negligence of the parties so released by such member or permit holder, by the hazards and risks so assumed by such member or permit holder, or otherwise. Such NWRA and NRA member or permit holder shall not now or at any time in the future, directly or indirectly, commence or prosecute any action, suit or other proceeding against the parties so released arising out of, or related to, the claims, demands, liabilities and other responsibility so discharged, waived and released by such member or permit holder. The undertakings and covenants of the foregoing provisions shall be binding upon each such NWRA member or permit holder, her spouse, heirs, legal representatives, successors, and assigns.

M.1.7 NWRA members (including contestants, permit holders and other members, in consideration of their membership and participation or other involvement in any capacity at NWRA sanctioned rodeos, do by their membership and participation agree to release, waive, discharge, and

covenant not to sue the NWRA and NRA and all sponsors (and such companies and their respective officers, directors, agents, and employees) from all claims, demands and liabilities for any and all property damage, personal injury, or other responsibility asserted or adjudged against any such member of members by any third parties arising from any such member's or member's participation or other involvement in NWRA sanctioned rodeos, except any such claims, demands or other liabilities asserted or adjudged against such member or members by a third party resulting from the gross negligence or willful misconduct of the NWRA and NRA sponsors (and/or such persons or entities affiliated, related and subsidiary companies and their respective officers, directors, and employees.)

M.1.8 A member of the NWRA who enters a sanctioned rodeo or rodeo event, and any, official or staff or other persons admitted to the rodeo shall, as a condition of entry, employment, admission or other involvement therein, be deemed to consent to the NWRA ownership of all rights in and to his or her appearance or other involvement therein, and the NWRA shall have the right, and may permit others as it sees fit, to dispense, reproduce and otherwise use any such person's name, voice, likeness, biography, photograph, and other pictures in connection with the advertisement and promotion of the rodeo or rodeo event and any reproduction thereof in any form, but not in conjunction with any statement constituting an endorsement by such person of any product or service unless that person's consent thereto is first obtained. A member of the NWRA who participates in sanctioned

rodeo events authorizes the NWRA to act in the member's behalf as well as in behalf of the NWRA in engaging in promotional activities relating to the conduct of the sport of rodeo.

M.1.9 NWRA members are not authorized to grant endorsements for the NWRA.

M.1.10 An individual applying for membership in the NWRA must submit an application using forms provided by the NWRA, and no application for a card or permit will be considered unless such application is on file in the NWRA office.

M.1.10.1 All individuals must purchase their card through the NRA/NWRA Office before they can enter a rodeo. The application must be signed, witnessed or notarized and have correct amount of money or it will be refused.

M.1.11 The dues paying year shall commence on December 1 of each year with the exception of the Finals Rodeo if it is held after the new fiscal year begins.

M.1.12 No membership will be processed without that person's social security number or tax identification number.

M.1.13 No membership will be renewed or processed if that individual has outstanding financial obligations to the NWRA.

M.1.14 It shall be the duty of each member of this Association to strive at all times to improve this Association in every way possible.

M.1.15 Memberships in this organization are non-transferable.

M.1.16 Any member of the Association who has a grievance against the Association shall follow the

proper grievance procedure as outlined in Section 7 of this rule book.

M.1.17 Any member of the Association who wishes to resign may do so in writing and it is her sole responsibility to do so. If she competes in one or more NWRA rodeos during the fiscal year she may not receive a refund on her card in case of an injury or any other circumstance.

M.1.17.1 Any member whose membership has been terminated for any reason other than voluntary resignation shall be deemed to have involuntarily resigned. A member will be deemed involuntarily resigned from the Association when that member, having been found guilty of an offense as defined in Section 7 has failed to satisfy all remedial obligations imposed by the Board of Directors, within 30 days following the Board's final determination. The 30-day period following any such final determination may be extended by the Board if the member, who is determined to have committed the said offense, requests an additional hearing and provided he posts with the NWRA office a monetary bond equal to the financial obligation imposed as a penalty for his infractions.

M.1.17.2 An involuntarily resigned member may apply for reinstatement 12 months following expiration of the dues-paying year in which involuntary resignation occurred. Such person desiring reinstatement must, prior to submitting reinstatement application, pay all previous debts to the NWRA and any obligations incurred while a member of the NWRA. Consideration of the application will only

be made when such obligations have been satisfied. All such applications for reinstatement will be subject to a reinstatement fee of not less than \$50. nor more than \$1,000. as may be set by the Board of Directors as a condition of reinstatement. The NWRA Board of Directors, may, upon consideration of all factors relating to the involuntary resignation, refuse reinstatement.

M.1.18 The Association urges its members to give all possible assistance to rodeo management.

M.1.19 This Association urges all management to attend Association meetings and banquets, and to further bolster cooperation.

M.2.1.0 MEMBERSHIP CATEGORIES:

M.2.1.1 Contesting Member: Annual dues shall be \$160 through May 1 of each year, and \$190 from May 1 forward. A competing membership card entitles member to compete in the two standard NWRA approved events: Ladies Barrel Racing and Ladies Break Away Roping. Any members in good standing of the Northern Women's Rodeo Association shall automatically be entitled to compete in the NWRA approved events.

M.2.1.2 Contesting Member membership entitles the purchaser to work all sanctioned rodeos without restriction, and to share in all advantages of a member in good standing, including such things as a guarantee of entry fee, check writing privileges after the first year of full membership, and a subscription to the newsletter, unless indicated.

M.2.1.3 First year Contesting Member and/or Rookie Classification: Any person who has

never held an NWRA card will have a “C” affixed on their membership card, unless a statement of credit reference from a bank officer is turned into the Association office. At that time, the “C” will be removed.

M.2.1.4 Rookie qualifications are as follows: First-year Contestant Card Member with the most money won in a particular event as of the end of the Rodeo Year, including money won through the Finals Rodeo. Member may not have won over \$500 in organized professional or regional rodeo competition during their lifetime.

M.2.1.5 Members are allowed to use Visa and/or MasterCard for purchasing memberships. A \$10 processing fee will be charged for each Visa and/or MasterCard use.

M.2.2 Annual permit dues of \$110. A contestant may purchase a permit if contestant has not won over \$500 in organized professional or regional rodeo competition during their lifetime. Permit holder can compete at all rodeos which accept permits until \$500 is won. The permit holder’s points will count toward year-end standings. After the \$500 money won limit is reached, a card must be purchased. Price of card will be the dollar difference between the cost of a permit and the cost of a card. However, the contestant must be a card holder to compete at the Finals rodeo. The \$500 money won limit will be accumulated from year to year, allowing the contestant to purchase a permit each year until \$500 is won. Permit holders are bound by the same rules as members. Once a membership card has been held, a permit cannot be purchased.

M.2.2.1 Any current National High School Rodeo Association member in good standing may purchase a NWRA permit at one-half regular price. Any National Intercollegiate Rodeo Association member in good standing may purchase a 1st year NWRA permit at one-half regular price. NHSRA & NIRA applicants must return a release properly signed and notarized or witnessed.

M.2.2.2 Unlimited One Rodeo Permit: A person may enter unlimited rodeos by purchasing a one rodeo permit based on the following scale:

\$200 - \$999 added in any event \$30

\$1,000 - \$1,999 added in any event \$40

\$2,000 and up added in any event \$50

Any money won by such permit holder shall not count towards the NRA standings or year-end awards. All One Rodeo Permits must have entry fees paid and a release signed 2 hours prior to the performance or slack advertised start time in which contestant is scheduled to compete in. If permit holder is drawn out of rodeo entered permit will not be refunded but may be used to enter another rodeo. No rodeo committee is required to accept one rodeo permits.

M.2.3 One companion pass will be issued for all card holding NWRA members (not including permit holders).

M.3.0 MEETINGS OF MEMBERS:

M.3.1 The annual meeting of the members of this Association (general membership meeting) shall be held each year during the finals, the place of the meeting to be decided by the Board of Directors. Written notice of the date of such meeting shall be sent to each member at least 15 days in advance of such

meeting. Election results for the coming year's officers will be announced at this meeting. Twenty members shall constitute a quorum at such meeting.

SECTION 2

B.1.0 OFFICERS AND BOARD OF DIRECTORS

B.1.1 General Powers: The Board of Directors shall have the power to conduct the business and affairs of the NWRA and the power to make, adopt, or amend the Articles of Incorporation, the Bylaws, and subject to the requirements in B1.1.2 the NWRA Official Rules of Competition. The Board of Directors may take any action it considers necessary or appropriate to carry out the purposes of the NWRA and may enter into any contract or obligation in furtherance thereof.

B.1.2.1 Rule change procedure for event rules of competition: Rule changes are to be proposed at the summer (August) and winter (NWRA Finals) meetings, with the board voting on the proposed rule changes at the spring (April) and fall (October) meetings.

B.2.1 The Officers of this Association shall be president, one vice president, one director at large, and one director for each of the two (2) events, and one director who shall be designated by the NRA as a liaison member.

B.2.1.1 Voting members of the Board of Directors include: president, vice president, director at large, three advisory board members, and one director representing each contest event (2), for a total of 8 votes.

B.2.1.2 Terms of directors as follows: All terms are for two years, and no candidates name shall

appear on the ballot for more than one office. The president, vice president, barrel racing event directors, will be voted on at the end of the fiscal year in the even numbered years. The break away roping director, director at large, and the NWRA Liaison Director will be voted on at the end of the fiscal year in the odd numbered years.

B.2.1.3 Ballots shall be electronic and published on the NWRA Website. The executive secretary shall be responsible for tabulating the votes after balloting has closed. The election results, including the vote totals for each candidate, shall be published on the NWRA Website.

B.2.2 A three-person Advisory Board shall be appointed by the President with the approval of the Board of Directors. Each Advisory Board director shall have a vote on the Board of Directors.

B.2.3 The director at large shall be the immediate past president of the organization and shall be a voting member of the Board of Directors.

B.2.4 Other ex-officio board members may be appointed by the president and the Board of Directors.

B.2.5 The president shall preside at all meetings of the Association and conduct the business of the Association in accordance with the Bylaws and other rules of the Association. The president shall be an ex-officio member of all committees. The president shall have authority to hire and fire employees of the Association.

B.2.6 The vice president shall perform the duties of the president when the president is absent from any meeting.

B.2.7 The executive secretary shall be an employee of the NWRA and shall keep the minutes of all meetings, keep and safeguard the records and funds of the Association, and shall be ex-officio secretary of all meetings and committees. The executive secretary shall be required to make a report of the activities of the Association and of the receipts and disbursements of funds for the past year at each annual meeting. The executive secretary shall make all payments from the Association funds by check. The president and executive secretary shall sign all written contracts of the Association.

B.2.8 The President or any two of the directors may call a special meeting of the Board of Directors at any time or any place including telecommunication provided that all members of the Board of Directors have been notified in advance.

B.2.9 A quorum of the Board of Directors shall consist of a majority of the members thereof and a majority of such quorum shall decide upon any questions which come before the meeting.

B.2.10 Proxy votes may be used however, a signed, notarized or witnessed consent from the absent director must be received prior to the meeting.

B.2.11 At the annual joint Board of Directors meeting held during the NWRA Finals Rodeo, the voting rights belong to the directors who have served the preceding term. The newly-elected directors shall be installed at the conclusion of the meeting.

B.2.12 All meetings attended by a representative for the NWRA must be previously approved by the President or Vice President. The government standard rate per mile shall be paid to the

representative for travel, and other expenses approved in advance will be reimbursed to the individual.

B.2.13 All vacancies on the Board of Directors shall be filled by the Board of Directors in a regular or special meeting and those so appointed shall serve until their successors have been duly elected and qualified.

B.2.14 Any officer or director may be removed by a majority vote of all the officers and directors at any meeting which has been called with proper notification. An officer or director may also be removed if the officer or director misses more than two meetings without representation or valid excuse, and the Board of Directors will appoint a replacement to fill the term of the removed officer or director.

B.2.15 It shall be the duty of the Board of Directors to promote and retain rodeos and they shall make every effort to work with rodeo management and the NWRA.

B.2.16 It shall be the duty of the president and the Board of Directors through the Association office to promote a publicity program for the Association. The results of all Association sanctioned rodeos will mailed to the newspapers within the Association area to help promote local interest.

B.2.17 Salaries of employees shall be established by the Board of Directors at a regular or special meeting.

B.2.18 At any time when there is a change in the office of executive secretary of the Association, it shall be the duty of the outgoing secretary to obtain from the incoming secretary, a signed receipt for all office equipment and supplies, as well as an acknowledgment of funds on hand at the time the

change is made. In the event the outgoing executive secretary fails to observe this rule the outgoing executive secretary shall be responsible for any shortages later discovered.

SECTION 3 - RULECHANGES

Rule change procedure for event rules of competition: Rule changes are to be proposed at the summer (August) and winter (NWRA Finals) meetings, with the board voting on the proposed rule changes at the spring (April) and fall (October) meetings.

SECTION 4 - INDEMNIFICATION

I.1.0 Third Party and derivative Actions.

The NWRA shall indemnify any person who was or is a party or is threatened to be made a party to any pending, threatened, or completed action, suit or proceeding, whether criminal, civil, administrative or investigative (including an action by or in the right of the NWRA), by reason of the fact that he is or was a director, officer, fiduciary, agent or employee or the NWRA, or is or was serving at the request of the NWRA as a director, fiduciary, officer, employee, or agent of another corporation, joint venture, partnership, trust or other enterprise, against expenses (including attorney's fees), judgments, fines and amounts paid or necessarily incurred, in settlement or otherwise, by him in connection with such action, suit or proceeding, all pursuant to section 35-2-446 M.C.A. et seq.

I.2.0 Determination. any indemnification provided for herein shall be made only as authorized by Montana law in effect at the time of indemnification.

I.3.0 Insurance. The Board of Directors may, pursuant to section 35-2-453 M.C.A. purchase and maintain insurance on behalf of any person who is or was a director, officer, fiduciary, employee, or agent of the NWRA, or is or was serving at the request of the NWRA as a director, officer, fiduciary, employee, or agent, against any liability asserted against that person and incurred by that person in any such capacity, or arising out of their status as such, whether or not the NWRA would have the power to indemnify them against such liability hereunder or otherwise.

I.4.0 Other coverage. The indemnification provided for herein shall not be deemed exclusive of any other rights to which persons seeking indemnification may be entitled under the Restated Articles of Incorporation, Bylaws, agreement, or Montana Non-profit Corporation Act, or otherwise.

SECTION 5

A.1.0 RODEO APPROVAL AND ADMINISTRATION

A.1.1 The NWRA provides its own NWRA rules for rodeo contestants and the rodeo committees must adhere to said rules.

A.1.2 Rodeo Committee shall be defined as any individual or group sponsoring a rodeo approved by the NWRA.

A.1.3 The NWRA reserves the right to withdraw its members from competition in any rodeo which does not conform to these rules.

A.1.4 Other than the Northern Women's Rodeo Finals, all NWRA sanctioned rodeos shall be open to all NWRA members in good standing, unless specific limitation is set forth in the rodeo's approval request.

A.2.0 RODEO APPROVAL:

A.2.1 All NWRA rodeos shall be co-sanctioned with the NRA and approval shall be based upon payment of all requisite fees to the NRA pursuant to the NRA rules.

A.2.1.1 Co-approved rodeos must be officially advertised.

A.2.2 At the time of a rodeo payoff, an additional 6 percent will be taken from the purse and entry fees for NWRA events.

A.2.3 An NWRA approved rodeo will have the ten standard events, which include: Bareback Riding, Saddle Bronc Riding, Bull Riding, Tie Down Roping, Steer Wrestling, Team Roping, Ladies Barrel Racing, Ladies Breakaway Roping, Junior Barrel Racing and Junior Breakaway Roping. All NWRA rodeos must also be co-approved by the NRA. All NRA rodeos must also be sanctioned by the NWRA.

A.2.4 A minimum of \$100 purse per performance in all adult events is required with a minimum of \$45 entry fees per person, per event, plus stock charge of \$8 per adult event (\$4.00 per man in the TR) \$5.00 central entry charge, \$5.00 judges fee, \$2.00 timers, \$2.00 secretary fee, \$4.00 finals fee with funds marked for the Finals payoff, and \$4.00 jacket fee with funds marked for the Finals jackets.

A.2.5 The Association President and any two members of the Board of Directors shall have the power to approve a rodeo. Such approval must be made sufficiently in advance so the membership may be informed of the rodeo.

A.2.6 All forms necessary for rodeo approval, judging, and payoffs will be furnished to the rodeo

committees to help promote the rodeo in a uniform manner.

A.2.7 Official added money for a rodeo cannot be changed after the final official advertising for that rodeo. Any additional added money may be included in purse paid out but it will not be counted as “official point” earnings.

A.2.8 The rodeo committee and /or stock contractor must notify Central Entry office prior to entry opening of the number of contestants per performance and slack.

A.2.9 The sponsoring committee of each NWRA approved rodeo shall be required to provide an ambulance and adequate first aid services for all paid performances and slack.

A.2.10 The sponsoring committee of each NWRA approved rodeo shall have a veterinarian present or on call.

A.2.11 Each rodeo will have the option of accepting non-member contestant entries. Each committee may determine the area for local entries. Local contestants must not be on the NWRA’s ineligible list. The NWRA accepts no responsibility for property damage, personal injuries, or other claims arising from local entries participating in NWRA sanctioned rodeos. All local entries must have entry fees paid and a release signed 2 hours prior to the performance or slack advertised start time in which contestant is scheduled to compete in.

A.2.12 Any local entrant found to be on the NWRA ineligible list after he/she has competed will be fined an amount equal to prize money won by that contestant at that rodeo.

A.2.13 Rodeo committees will be responsible for provision of a conveyance to be used in the event of injury to animal requiring removal from the arena.

A.2.14 No cancellation of a performance will be permitted unless the opinions of the committee chairman, stock contractor and Association officials deem it a physical impossibility to hold the performance.

A.2.15 The Association reserves the right to withdraw its members from competition in any rodeo which does not conform to these rules.

A.2.16 No rodeo committee is required to accept permits.

A.2.17 Rodeo committees will be responsible for proper preparation of the arena and adjacent grounds, the preparation to include the removal of feed, waste, dust, and any other debris deemed undesirable.

A.2.18 Stock is not to be fed in the arena during the duration of the rodeo. If the stock must be fed in the arena, the rodeo committee must have the arena worked satisfactorily the same for all performances and slack.

A.2.19 NWRA Committees or contractors must hire at least one certified timer. Certified timer defined as a timer who is experienced and has attended an NWRA or NRA timers clinic/seminar. Individuals who have attended a timers clinic/seminar, but who are not experienced, are required to time a rodeo with two experienced timers in order to gain full certification.

A.2.20 If a stock contractor declines an existing rodeo or cannot reach agreement on the bidding for said rodeo shall be open to all NWRA

approved stock contractors. Unreasonable terms shall be determined by the advisory board.

A.2.21 Any Committee receiving a NWRA rodeo approval shall allow any NWRA Member (including Permit Members if that rodeo accepts Permit Member entries) access to rodeo grounds if valid NWRA membership card is presented.

A.2.22 The minimum added money to have a short-go rodeo is \$1,500.00 per event. The fees at a short-go rodeo will be \$125.00 per event.

A.2.23 In the all events the following scale of entry fees to added money shall apply:

\$100-\$299 added money.....\$45 entry fee

\$300-\$499 added money.....\$50 entry fee

\$500-\$999 added money....\$60 entry fee

\$1,000 up added money.....\$75 entry fee

Short-go rodeos with \$1,500 added per event.....\$125.00

A.2.24 All rodeos shall be drawout rodeos unless rodeo has added money of \$1,000 per event or more. If rodeo adds \$1,000 per event or more that rodeo has the option of being a no drawout rodeo.

A.2.25 If sanction is received in NRA/NWRA Office by April 1 committee may put a maximum of 4 judges they don't want to judge their rodeo. This is a consideration for the NRA Judging Committee.

A.3.0 RODEO ADMINISTRATION:

A.3.1 Judges will be paid a minimum of \$125 per performance (slack being considered a performance) by the Stock Contractor or Committee.

A.3.2 Minimum pay for NWRA card-carrying timers will be \$75 per performance. There will be a \$2.00 charge per contestant at each rodeo. The two

dollars will be split evenly among the timers.

A.3.3 There will be a \$5.00 charge per contestant at each rodeo. The five dollars will be split evenly among the judges, with NRA/NWRA approved judges receiving their split and the amount designated for the unapproved judge will be forwarded to the Association office for the judging program.

A.3.4 The rodeo committee or stock contractor, which provides the arena secretary, will be responsible for the secretary's action, and will be liable for the secretary's mistakes or discrepancies in the payoff or in the handling of entry fees in the event the secretary does not make the proper adjustment.

A.3.5 Any mis-handling of funds or issuing of fraudulent checks by a stock contractor, rodeo secretary, or rodeo committee, will require the posting of a \$10,000 fidelity bond or \$10,000 cash bond with the NWRA before they will be allowed to participate in another NWRA approved rodeo.

A.3.6 Timers for a rodeo may not be changed after the first performance except for sickness or injury, by request of an Association official because of timer's incompetence, or through agreement of stock contractor, rodeo committee, and Association official.

A.3.7 Timers must work from the same location for the duration of the rodeo.

A.3.8 Any hand timing for NWRA events will be timed in tenths. (the 100th will be dropped from the time and all places paid on tenths). Example: 9.67 is a 9.6; 9.43 is a 9.4; 8.99 is an 8.9.

A.3.9 Two or more timers will use hand-held digital watches and record the average of two times at all rodeos, ignoring any digits beyond the tenths.

A.3.10 Management must provide a place for official timers and announcer to work without obstruction or interference and at a place that will facilitate good communications with arena director, judges, and announcer.

A.3.11 If both timers miss the start or stop of the run (timed events) or if both watches malfunction, the contestant receives a re-run.

A.3.12 A rodeo committee, rodeo producer or stock contractor which hires non-member Contract Personnel will be subject to a \$500 fine per rodeo, per individual hired.

A.3.13 There will be a \$2.00 charge per contestant at each rodeo. The two dollars will be paid to the rodeo secretary.

A.4.0 CENTRAL ENTRY, SECRETARY, AND RODEO OFFICE:

A.4.1 Central Entry is the ONLY entity that can accept entries for NWRA rodeos.

A.4.1.1 When a contestant telephones or enters a rodeo through central entry before the entry closing time, her name is to be put on the books.

A.4.1.2 When entering, every member contestant must give her Association number and is responsible for all non-member contestants entered by the member. All non-members entering an Association rodeo will be drawn out if entries are not paid or guaranteed by a member in good standing when entries close.

A.4.1.3 If you do not receive your 1st or 2nd preference you may draw out during callbacks.

A.4.1.4 Contestants cannot choose the same performance for their 1st and 2nd preferences when entering rodeos.

A.4.1.5 Contestants may use draw out as a second preference when entering rodeos.

A.4.2 Preference of performance when drawing positions will go first to the contestants entering the greatest number of NWRA rodeos for the given entry period. Preference will be based on rodeos entered by entire buddy group. Members will receive preference over local entries.

A.4.3 Slack may be used as a first preference when entering an NRA/NWRA rodeo. All slacks are as necessary.

A.4.4 When entering, the buddy system will be limited to four contestants, six positions total. NWRA members may only buddy with a rough stock contestant if they are a husband or immediately family. Must have proper documentation.

A.4.5 Dates and times of the draw can be listed on the website. The time and place of the stock draw will be made available upon request of the contestant at the time of callbacks.

A.4.6 Positions are drawn by Central Entry Office. There will be no placing of contestants. All rodeos will be trade-out rodeos unless otherwise advertised.

A.4.7 No one can change a position at the rodeo without approval or action of the Central Entry Office unless it is in accordance with specific rules (tradeouts, etc.) as outlined in this rulebook. Any such change will subject person(s) to a fine of \$500 for first offense and six months suspension for a second offense.

A.4.8 Slack is to be run in the same order of events as the rodeo, with Ladies Barrel Racing run first.

A.4.9 Rodeos must have a minimum of 8 contestants in all timed events per performance.

A.4.10 In the case where contestants enter a selected 'preference or draw out' and are drawn out, they may re-enter for either their selected preference if it is not filled or any unfilled positions. Priority will be given on a random draw. Re-entries date and time will be published on the website. Draw outs may also be used to replace TO and release up to notified turn out deadline.

A.4.11 The order of performance events may not change once a go-round has started without the consent of the event representative, all judges and Rodeo Committee. If the events are changed and a contestant gets turned out because of the change, contestant should be assigned his original stock, if possible.

A.5.0 SECRETARY AND RODEO OFFICE:

A.5.1 Any member who intends to act as a rodeo secretary must notify the Association of their intentions so that they can be sent the Association mailings of secretary information. Secretaries who work more than one rodeo will be required to attend a secretary's clinic to be eligible. Also, secretaries and timers who work more than one rodeo will be required to buy an NWRA secretary or timer card.

A.5.2 All NRA Secretaries are required to use the NRA Secretary software. Secretaries shall submit rodeo results to the NRA Office immediately following the final performance. Each completed rodeo is to be

uploaded to the NRA Office no later than 10:00 am the Monday morning following completion of the final performance of a rodeo. Failure to abide by this Bylaw shall result in a \$100 fine.

A.5.3 ALL CONTESTANTS ARE REQUIRED TO READ THE RULES CAREFULLY, PARTICULARLY THOSE RELATING TO THE CONTESTS OR EVENTS IN WHICH THEY ENTER. Failure to understand rules will not be accepted as an excuse.

A.5.4 A rodeo will not be responsible for the returning of a contestants entry fee if she has contested in an event once during a rodeo. If she is entered in other events in which she is unable to contest, the entry fees for those events must be returned.

A.5.5 A contestant turning out in any event may contest in the rest of her events with payment of her turnout fees in those events in which she didn't compete. No stock shall be brought back after turning out. Such contestants will not be eligible for average money in the event in which she has turned out stock. Stock so turned out can be used for re-runs.

A.5.6 Each NWRA member will be responsible for her entry fees regardless of who issues the check.

A.5.7 Members must make checks good to the NWRA or be placed on the ineligible list and prosecuted to the full extent of the law.

A.5.8 NWRA will not honor nor be responsible for NSF checks turned into the NWRA office by a rodeo committee, stock contractor, or secretary if the date of the check is more than 30 days prior to receipt by the NWRA office.

A.5.9 NWRA permit holders will be required to pay entry fees in cash.

A.5.10 Permit holders may contest at such NWRA rodeos where permits are accepted.

A.5.11 NWRA members in good standing and not on a “cash only” basis, may guarantee another NWRA member’s fees. Rodeo secretaries will record the card number of the member making the guarantee.

A.5.12 If a contestant shows up to compete on a day other than the day they are actually up on according to the rodeo secretary, before competing in that rodeo, the contestant must post a bond in the amount of \$100. If, after verification with Central Entry, the contestant was correct, the bond will be refunded. If the contestant was in error, the bond (fine) will be forfeited, contestant suspended, contestant’s fees figured in the payoff and the proper payoff will be paid out, disregarding said contestant’s placing.

A.5.13 Turn-out fees and fines will be sent to the NWRA office and applied to the Finals purse.

A.5.14 Turn-outs and releases are not figured into the payoff unless fees were collected at the rodeo.

A.5.15 A contestant is allowed a total of two (2) releases in a rodeo year. Additional releases beyond two (2) will result with a \$150 fine and you are ineligible to compete until the fine is paid. If contestant is releasing out of a rodeo they must notify the NWRA office prior to performance or slack they are up in. If no one is available in NWRA office contestant must leave voicemail. A contestant who releases shall not be eligible to compete in that event for five (5) days, beginning with the first performance or slack release is used. A contestant who releases in one event may compete in another.

A.5.16 A \$10 processing fee will be charged for each rodeo that a release is used by a contestant.

A.5.17 No rodeo which completes its contract shall be responsible for the returning of a contestant's entry fees if she has contested in an event during the rodeo. If she is entered in other events in which she is unable to contest, the entry fees for those events must be returned.

A.5.18 If a contestant is injured while competing, her entry fees will be refunded in any events in which she cannot compete because of the injury.

A.5.19 If, in the opinion of the judges, a contestant is unable to compete in a particular event because of injury, she may withdraw, but this does not prevent her from competing in other events in which she is entered.

A.5.20 After stock is drawn the secretary may not refund any entry fees without approval of judges, rodeo producer or Association director.

A.5.21 Notified Turnouts: If a contestant notifies the NWRA office before 3 p.m. on the last working day before the first performance or slack of the given rodeo, the contestant is responsible for their fees in all events entered, plus a \$20 fine per contestant, not event. Each individual rodeo secretary must call the NWRA office between 3:00 and 4:00 p.m. on the last working day before the first performance or slack of their rodeo to receive their list of notified turnouts for the rodeo. Fees that are received by the NWRA office or by the rodeo secretary thru and including the last performance will be included in rodeo payoff. All fine monies collected will be credited to the finals account.

A.5.22 Entry fees must be paid or arrangements made for payment prior to the payoff for that event or contestant is subject to a \$250 fine plus her fees for the first offense and double thereafter per event per rodeo.

A.5.23 Turn-outs: When a contestant turns out, if a contestant's fees are paid at the rodeo and included in the payoff for that rodeo, a fine will assessed equaling 1/2 (one half) the entry fee. If a contestants fees are not included in the payoff, he will be responsible for a fine equal to his fees, plus his fees, and administrative costs, i.e. central entry charge, stock charge, and judges charge. Collected fine monies are not included in payoff and are to be sent to the NRA office. Fees that are received by the NWRA office or by the rodeo secretary thru and including the last performance will be included in rodeo payoff.

A.5.24 Management shall make every effort to provide a weatherproof building or enclosure suitable for use as a rodeo office (excluding the announcer's stand). This facility should be provided with electricity, and where possible, telephone.

A.6.0 POINT AWARDS AND PAYOFF:

A.6.1 The Association point award system has been established for the purpose of determining the champion cowgirl at the end of the rodeo season.

A.6.1.1 The end of the rodeo year shall be the first Sunday in November. All Championship Points won in a rodeo completed before midnight on the rodeo year cutoff date shall be counted in the Official NRA Standings for that rodeo year.

A.6.2 The Association will figure its points on a basis of one point per dollar won, and the most

points accumulated in any two or more events will determine all-around champions at the end of the year. Contestant must win a minimum of \$500.00 in each of two events to be eligible for the all-around.

A.6.3 There will be no ground split money paid.

A.6.4 Payoff will be four monies unless go-around payoff exceeds \$1,000. Five places will be paid if the payoff is \$1,001 up to \$2,000; six places, \$2,001 up to \$3,000; eight places, \$3,001 up to \$5,000; ten places, \$5,001 and up.

Payoff split is as follows:

Four places: 40%, 30%, 20%, 10%.

Five places: 34%, 26%, 20%, 13%, 7%.

Six places: 29%, 24%, 19%, 14%, 9%, 5%.

Eight places: 28%, 23%, 18%, 13%, 8%, 5%, 3%, 2%.

Ten places: 25%, 20%, 14%, 12%, 9%, 6%, 5%, 4%, 3%, 2%.

A.6.5.0 On three head of stock the average will be one and one-half times the go-around money in all of the above events.

A.6.5.1 On four head of stock the average will be twice the go-around money in all of the above events.

A.6.5.2 On five or more head of stock the average will be three times the go-around money in all of the above events.

A.6.5.3 The average will never exceed three times the go-around money.

A.6.5.4 Payoff for a one go-around/short go-around rodeo is as follows: 40% long go; 20% short go; 40% average.

A.6.5.5 At two go-around same day rodeos with doubled fees, the monies will be split in thirds: 1/3 first go, 1/3 second go, 1/3 average, and the number of places paid out will be determined by the amount of money after the 1/3 breakdown and percentages found in rulebook. (Example: 9 contestants \$70 fees = \$630 + \$150 added money = \$780 x 4% = \$31.20; \$780 - \$31.20 = \$748.80 divided by 3 = \$249.60 per go/ave. Use 40/30/20/10 payoff).

A.6.5.6 When less than the number of contestants place in an event than the proper payoff for that event, the remaining places shall be divided evenly among those contestants who did qualify (have a score or a time). That money shall be considered ground money and will not be posted as Championship points. If all contestants fail to qualify, the entry fees and added money for that event will be sent to the NWRA office to be included as added money for the NWRA Finals rodeo allowing contestants to compete back at that money.

A.7.1 No shows/turnouts are not figured into the payoff. When they are collected they will be added to the year-end finals purse.

A.7.2 A contestant must compete on every head of stock drawn for her in an event to place in the average.

A.7.3 Contestants are to be paid any money won in a complete go-around.

A.7.4 Prize money and entrance fees must be totaled for go-around monies and average.

A.7.5 Six percent (6%) shall be held out at the payoff (prize money and entry fee) three percent (3%) to go to the Association, and three percent (3%) to the

association finals rodeo prize money. The six percent (6%) shall be taken off the total payoff before any payoffs are made.

A.7.6 If contestant's fees are paid, but the contestant turns out, the money is figured into the payoff for the event.

A.7.7 Prize money shall be paid by check.

A.7.8 If contestant competes but does not pay his/her fees, the money is figured into the payoff for the event.

A.8.0 TRADE OUTS, TURN OUTS

A.8.1 All NWRA rodeos are trade-out rodeos unless advertised as "NO TRADE OUTS."

A.8.2 Trades: A contestant may trade positions and/or performance of competition with another contestant at any time after entries close, provided it is before the draw for that event. In the Ladies Barrel Racing the trade must be 2 hours before the start of slack or performance.

A.8.3 If a trade is completed before callbacks close, trades are handled through central entry.

A.8.4 After callbacks all trades are handled through the NWRA office.

A.8.5 Both parties involved in the trade must call the NWRA office and confirm the trade.

A.8.6 Trades can be made at the rodeo upon consent of both parties involved before the draw in that event. both judges and rodeo secretary must be notified of trade by BOTH parties involved in trade.

A.8.7 Only the contestant who qualifies for a short round will be traded at the conflicting rodeo.

SECTION 6

D.1.0 DISCIPLINARY ACTION AND CONDUCT RESTRICTIONS

Any member may be subject to reprimand, fine, suspension, or expulsion, by action of the NWRA Board of Directors, or by action of an officer or committee to whom the Board of Directors has delegated such authority, for commission of any of the following prohibited acts:

D.1.1 Writing a bad check made payable to the NWRA, NRA a rodeo secretary, stock contractor, or rodeo committee in conjunction with a NWRA approved rodeo.

D.1.2 Nonpayment of entrance fees or any financial obligation incurred in conjunction with a member's attendance or participation at a NWRA approved rodeo.

D.1.3 Failure to reimburse the rodeo secretary or NWRA office for overpayment of prize money.

D.1.4 Turning out during a performance or slack when the contestant is present, able and healthy enough to perform.

D.1.5 Any other action or conduct found to be in violation of the rodeo rules or the Articles or Bylaws of the NWRA which results in a fine to the member, although not specifically listed.

D.2.0 The Board of Directors may delegate responsibility for rule infractions such as nonpayment of entry fees, failure to compete after entry and similar violations to the NWRA staff. In such cases, the NWRA staff shall have authority to impose fines and declare contestant ineligible.

D.3.0 As a corrective or disciplinary measure,

the Board of Directors has formed a Rules Infraction Committee, made up of the members of the NWRA Advisory Board, Vice President, President, and Director at Large, hereinafter referred to as RIC. The Board of Directors may delegate authority to RIC to impose fines and other disciplinary measures for rule offenses.

D.4.0 Following is a breakdown of offenses that will result in disqualification and/or fines. A judge has the authority to assess fines. A contestant will not be allowed to compete at the next rodeo until their fines have been paid. Remedies for protesting a fine or disqualification are outlined below. A contestant will be subject to the following if an offense occurs during a paid performance or slack:

D.4.1 A contestant will be disqualified for the following offenses: Refusing to contest on an animal drawn for them; not being ready to compete when called upon.

D.4.2 A contestant will be disqualified and fined \$50 for the following offenses: being under the influence of liquor in the arena; rowdyism or quarreling on and around the rodeo grounds; using foul or abusive language in the arena or on the rodeo grounds.

D.4.3 A contestant will be disqualified and fined \$250 for the following offenses: first offense of mistreatment of animals, in or out of the arena. Second offense will be disqualification and a fine of \$500. An offense, thereafter, will result in suspension for a period of one year from NWRA rodeos; cheating or attempting to cheat; false communication with central entry regarding NWRA rodeo entry procedure.

D.4.4 No one can change a position at the rodeo without approval or action of the Central Entry Office unless it is in accordance with specific rules (tradeouts, etc.) as outlined in the NWRA rulebook. Any such change will subject person(s) to a fine of \$500 for first offense and six months suspension for a second offense.

D.4.5 A member of the NWRA that harasses, intimidates, or threatens and NRA official, central entry staff, office staff, board member or anyone affiliated with the NRA will be disqualified, if applicable, and fined \$500 for the first offense. If this offense occurs at any time other than a rodeo, the individual will be fined \$500 for the first offense.

D.4.6 Upon the second offense, the member will be disqualified, if applicable, fined \$1,000 and will be subject to suspension as determined by the Rules Infraction Committee (RIC).

D.4.7 A contestant will be fined \$25 for not wearing a western hat or helmet, western boots, long sleeved shirts that are collared and have either buttons or snaps on the front of the shirt and jeans without holes while in the arena, on the bucking chutes, or on the sides and/or backs of roping boxes during performances or slack. Any contestant being assisted in any manner by an individual not adhering to this dress code will be fined \$25. Any contestant who competes in violation of dress code will be disqualified.

D.4.8 Submitting a fraudulent letter of bank credit to the NRA Office

D.4.9 Going on strike after entering an NWRA approved rodeo without authorization and approval from the NWRA Board of Directors.

D.5.0 Standard Fine Schedule: The following is a list of standard fines which will be imposed for certain conduct violations unless the conduct of the member is aggravated, in which case a more severe penalty or discipline may be imposed.

D.5.1 Non-sufficient fund checks: The member shall be fined \$100 per non-clearing check, plus the amount of the check. The member shall be immediately suspended, until the check has been made good. The member will then have a "C" placed on her membership card, requiring her to pay in cash only. If rodeo secretary is assessed a service charge, the secretary will be reimbursed for charge when confirmation of service charge is submitted to NWRA Office along with NSF check.

D.5.2 The Association will not pay checks written for cash.

D.5.3 Only entry fee checks will be honored.

D.5.4 If a member ever writes a bad check and is put on the ineligible list, she must pay cash the remainder of that year, then the following year she must present a letter of accreditation or a check cashing guarantee card to the association Board of Directors for reinstatement of check writing privileges. If there is a second offense, she is placed on a permanent cash list.

D.6.0 The NWRA (rodeo secretaries included) will not accept checks drawn on a Canadian bank.

D.7.0 Any contestant turning out her stock, or refusing to contest on an animal drawn for her, during a paid performance at a rodeo when she is present, able and healthy enough to contest, is subject to disciplinary action as follows;

D.7.1 Disqualification in all events for the remainder of the rodeo.

D.7.2 First offense: \$50, second offense: \$100, third offense: \$200;

D.8.0 No contestant will be declared ineligible because of being charged for an overpayment until notified and allowed 15 days to pay.

D.9.0 Turnouts: Turnout fine will match the entry fee and all additional charges (stock charge, central entry charge, judges charge, etc.) Ineligibility: violators will be ineligible to enter in NWRA rodeos effective five (5) business days from the date of the last performance which turn-out occurred and will not regain eligibility until such time as fees and fine are paid in full.

D.10.0 Contestants may not change their position at the rodeo without approval or action of the central entry office unless it is in accordance with specific rules as outlined in the NWRA rulebook. Any such change will subject contestant to a fine of \$500 for first offense and six months suspension for a second offense.

D.11.0 Failure to wear contestant number when required shall result in a \$10 fine.

D.12.0 Any willful attempt by a member of the NWRA to intentionally break the rules of the NWRA will be fined \$100 and could be denied participation in the Finals rodeo and year-end awards.

D.13.0 Contestant Disqualifications: Members shall be disqualified in all events for the remainder of the rodeo and/or subject to disciplinary action for any of the following offenses:

D.13.1 Contestant will be disqualified for

being in a pen with livestock at any time, except when accompanied by arena director, judge, stock contractor, or when assigned to work in those pens.

D.13.2 No contestant may be disqualified from a rodeo for a period to exceed one year without the express consent of the Board of Directors.

D.13.3 A contestant can be disqualified immediately and suspended by an acting, approved judge and/or the arena director at rodeo where the violation occurred.

D.16.0 DISCIPLINARY PROCEDURES:

The following disciplinary procedure shall be applied in the event a member is reported for any alleged rule violation or misconduct. It is the purpose of these procedures to afford each member a fair investigation and an opportunity to fully explain her position prior to the imposition of final disciplinary action.

D.16.1 The Board of Directors has created the Rules Infraction Committee (RIC) to function as a preliminary review committee with respect to rule infractions. RIC shall have authority to investigate, propose, or levy disciplinary action against members. RIC may in their discretion reduce the amount of a fine or modify a penalty.

D.16.2 Contestants found to be in violation of NWRA rules may, in addition to fines, reprimands, suspension and the like, be subject to loss of point standings won while in violation of a rule.

D.16.3 Any member who wishes to dispute a final disciplinary action taken against the member under this chapter shall utilize the Grievance procedure set forth in the following section.

D.16.4 As a condition of membership, all member-participants in NWRA approved rodeos affected in any manner whatsoever by decision of the NWRA Board of Directors, RIC, or any person or committee authorized by the NWRA Board of Directors to handle disciplinary matters, hereby releases the NWRA, their affiliated, related or subsidiary companies, their officers, directors, and employees, members, jointly and severally, individually, and in their official capacity, of and from any and all claims, demands, damages, and causes of action whatsoever, in law or equity, arising out of or in connection with any disciplinary decision or action by the NWRA or by the individuals or committees to whom disciplinary matters may be authorized by the NWRA or RIC.

D.16.5 Remedies for protesting disqualifications or fines:

D.16.5.1 A written letter of objection must be submitted to the NWRA office within seven (7) days of being notified of the offense. The letter must contain, at the minimum, a thorough explanation of the incident and the individual's reasons of objection. Appeal to be heard by the Rule Infraction Committee. All fines, as mentioned above, must be paid even if an individual submits the letter of objection. See section 7 for complete grievance procedure.

SECTION 7

G.1.0 GRIEVANCE PROCEDURE

G.1 As a condition of membership, all members agree that any dispute with the NWRA, its officers or directors, shall be resolved through the following grievance procedure. Any member

may utilize such procedure to question or contest any action of the NWRA or to challenge any Bylaw or contest any action of the NWRA involving application or interpretation of the NWRA Articles of Incorporation, Bylaws or Official Rules of Competition. Should the member desire to be permitted to contest or participate in NWRA events during the pendency of his or her grievance, a cash bond must be posted. In the event of a disciplinary suspension, a cash bond in an amount determined by RIC of not less than \$1,000 shall be posted.

G.2 Step 1. The grieving member shall bring the subject matter of the member's grievance to the attention of RIC in writing within seven (7) business days of receipt of notice of action being taken by the NWRA. The letter shall set forth in full the subject matter of the dispute and the proposed action requested by the grievant. Within 15 business days following receipt of said Step 1 grievance letter, RIC shall reply in writing to the grievant, setting forth their decision on the matter. Said decision shall be final and binding unless appealed by the grievant to Step 2.

G.3 Step 2. In the event that the grieving member is dissatisfied with the decision of RIC, he or she may appeal directly to the NWRA Board of Directors. The member shall serve a notice of appeal on the NWRA Board within 15 (fifteen) days of the receipt by the member of the written decision of RIC. Said notice of appeal shall set forth the full position of the member regarding the action taken by RIC including but not limited to the specific grounds of the appeal any mitigating circumstances and any other grounds for disputing the discipline imposed.

G.4 Service of the notice of appeal shall be accomplished by either personal service on the President or Executive Secretary of the NWRA or by receipt of the notice at the business address of the NWRA by certified or registered mail return receipt requested. In the event of mailing the notice, the date of receipt shall be deemed the date of receipt noted on the U.S. Postal Service records.

G.5 Upon receipt of the member's notice of appeal, the NWRA Board shall convene in special meeting called for the purpose of considering the appeal. Notice of hearing shall be sent to the member and all board members. The hearing shall be conducted pursuant to the most recent revision of Roberts Rules of Order. The member may present all relevant evidence in support of member's appeal. The board shall then receive any other evidence pertaining to the issues presented on appeal. After receiving the evidence, the board shall issue the final decision on the matter. Such decision shall be final and binding on all parties.

H.1.0 RULES TO INSURE THE HUMANE TREATMENT OF LIVESTOCK

H.1.1 Any flagrant abuse of animals, either in or out of the arena, will not be tolerated. A contestant will be disqualified and fined \$250 for: First offense of mistreatment of animals, in or out of the arena. Second offense will be disqualification and fine of \$500. An offense, thereafter, will result in suspension for a period of one year from NWRA rodeos.

H.1.2 Animals for all events will be inspected before the draw, and no sore, lame, sick or injured animal, or animals with defective eyesight shall be

permitted in the draw at any time. Should an animal become sick or be injured between the time it is drawn and the time it is scheduled to be used in competition, that animal shall not be used in competition, and another animal will be drawn for the contestant as provided in the rulebook.

H.1.3 No animal shall be beaten, mutilated, or cruelly prodded. Standard electric prods shall be used as little as possible. Animal shall be touched only on the hip or shoulder area.

H.1.4 Rodeo committees will be responsible for provision of a conveyance to be used in the event of injury to animal requiring removal from arena. Animals removed from the arena pursuant to this section shall be placed in a situation as isolated and comfortable as possible to reduce stress.

H.1.5 Animals will be released from the chute if they become excessively excited and fight the chute and are in danger of injuring themselves.

H.1.6 Chutes must be so constructed as to prevent injury to stock. Maintenance men and equipment shall be stationed at chutes to assist in removal of any animal should it become caught. The arena shall be free of rocks, holes, and obstacles.

H.1.7 No small animal or pets are allowed in the arena where restraint is necessary, or subject to injury or attack by another animal.

H.1.8 Livestock is to be removed from the arena after completion of entry in contest.

H.1.9 A veterinarian shall be present or on call at all performances and slack.

H.1.10 Use of fireworks to frighten animals is prohibited.

H.1.11 Any injured livestock shall be humanely removed from the arena before continuing the rodeo contest or performance.

J.1.0 JUDGING PROGRAM

J.1.1 The NWRA will initially utilize judges supplied by the NRA and shall utilize the NRA's judgery program. All judges in NWRA events shall be qualified NRA judges..

J.1.2 Judges will be evaluated periodically during the summer.

J.1.3 Additional details concerning the judging program will be addressed by the Board of Directors, as necessary. *Special Note: A judge that does not meet the qualifications as defined above and judges an NWRA approved rodeo will only be paid as required in sections concerning rodeo administration.

J.1.4 Contestants will pay \$5.00 in their entry fee to the judges.

J.1.5 All beginner judges will do the draw and set up the barriers at the rodeos with the experienced judge overseeing.

J.3.0 Complaints Against Judges

J.3.1 Valid complaint:

J.3.1.1 All complaints against judges shall be presented to the Judging Committee for review by the Judging Committee. The Judging Committee will investigate each complaint to determine if there is a reasonable basis for the complaint. The following may constitute a basis for a complaint against a judge:

Any violation of the rules or by-laws of the Association by a judge during a rodeo or rodeo related event.

Any action by a judge which reflects negatively on the sport of rodeo or the Association and its members
Being under the influence of drugs or alcohol while officiating a rodeo.
Rowdyism or quarreling on or around the rodeo grounds
Cheating, attempting to cheat or any other fraudulent action by a judge
Gross negligence in scoring the rough stock events
Gross negligence in timing or flagging a timed event

If the Judging Committee determines there is a reasonable basis for a complaint, the complaint shall be deemed valid and the Judging Committee may take any of the actions set forth herein:

J.3.2.1 One (1) valid complaint during one rodeo season, shall be the basis for notification to the judge, in writing, by the Judging Committee of the complaints, and censure of the judge.

J.3.2.2 If a judge receives two (2) valid complaints during one rodeo season, the judge shall be required to appear before the Judging Committee to answer the complaints and explain their actions. At such hearing the Judging Committee may, at their discretion, recommend to the Board of Directors the following:

No action be taken; or

The judge be reduced to the next lower rank on the judges rankings; and/or,

The judge be placed on probation for the remainder of the year; and/or,

Suspend the judge for up to one (1) year; and/
or,

Require the judge to successfully complete a judging seminar or conference.

J.3.2.3 If a judge receives three (3) valid complaints in one rodeo season, the judge will be required to appear before the Board of Directors to answer the complaints and explain their actions. At this time the Board of Directors may impose any of the sanctions set forth in Rule J.3.2.2 above and/or may suspend a judge indefinitely.

J.3.2.4 Any judge suspended will be required to complete a judging seminar and will be put on probation for the first year following reinstatement. If a complaint is filed against a judge on probation and is determined to be valid, the Judging Committee or the Board of Directors may suspend the judge immediately and indefinitely.

J.3.2.5 Any judge receiving a number five (5) rating will be automatically suspended for one year. Any judge receiving a number four (4) rating two (2) years consecutively will automatically be suspended for one year.

RULES OF COMPETITION

R.1.0 ARENA RULES

Following is a breakdown of offenses that will result in disqualification and/or fines. A judge has the authority to assess fines. A contestant will not be allowed to compete at the next rodeo until their fines have been paid. Remedies for protesting a fine or disqualification are outlined below. A contestant will be subject to the following if an offense occurs during a paid performance or slack.

R.1.1 A contestant will be disqualified for the following offenses:

a. refusing to contest on an animal drawn for them.

b. not being ready to compete when called upon.

c. the judges have the discretion to make the determination that the contestant is delaying the rodeo unnecessarily and may disqualify contestant and/or impose a fine.

R.1.2 A contestant will be disqualified and fined \$50 for the following offenses:

a. Being under the influence of liquor in the arena.

b. Rowdiness or quarreling on and around the rodeo grounds.

R.1.3 A contestant will be disqualified and fined \$100 for the following offenses:

a. First offense of mistreatment of animals, in or out of the arena. Second offense will be disqualification and a fine of \$500. An offense, thereafter, will result in suspension for a period of one year from NWRA rodeos.

b. Cheating or attempting to cheat.

R.1.4 No one can change a position at the rodeo without approval or action of the Central Entry office unless it is in accordance with specific rules (tradeouts, etc.) as outlined in the NWRA rulebook. Any such change will subject person(s) to a fine of \$500 for first offense and six months suspension for a second offense.

R.1.5 A member of the NWRA that harasses, intimidates, or threatens an NWRA official or Board

member will be disqualified, if applicable, and fine \$500 for the first offense. If this offense occurs at any time other than a rodeo, the individual will be fined \$500 for the first offense. Upon the second offense, the member will be disqualified, if applicable, fined \$1,000 and will be subject to suspension as determined by the Rules Infraction Committee (RIC).

R.1.6 A contestant will be fined \$25 for not wearing a western hat or helmet, western boots, long sleeved shirts that are collared and have either buttons or snaps on the front of the shirt and jeans without holes while in the arena, on the bucking chutes, or on the sides and/or backs of roping boxes during performances or slack. Any contestant being assisted in any manner by an individual not adhering to this dress code will be fined \$25. Any contestant who competes in violation of dress code will be disqualified.

R.1.7 Each contestant shall be responsible for knowing which stock they are to compete on. In the timed events, the contestant that competes on the wrong stock is disqualified and the stock should be brought back so that the contestant that drew that stock must compete on that stock, unless that stock has been injured, then the extra is used.

R.1.8 All contestants are required to ride in the grand entry if they have a horse. Also, winners of an event at a rodeo should be ready to ride into the arena when their name is called.

R.1.9 If numbers are supplied and not worn, contestants are subject to a \$10 fine.

R.1.10 Any ground rules made will have to be approved by the Board of Directors.

R.1.11 Slack is to be run in the same order of events as the rodeo, with the Ladies' Barrel Racing

being run first.

R.1.12 Any judges failing to comply with these instructions will be declared ineligible. Infractions shall be reported to the office by the event directors or representatives and a \$100 fine will be levied against the stock contractor and each judge in violation.

R.1.13 All contestants are required to make an honest effort. Failure to do so shall result in a \$25 fine to be imposed by the judge or judges.

R.1.14 Remedies for protesting disqualifications or fines:

A written letter of objection must be submitted to the NWRA office within seven (7) days of being notified of the offense. The letter must contain, at the minimum, a thorough explanation of the incident and individual's reasons of objection. Appeal to be heard by the Rules Infraction Committee. All fines, as mentioned above, must be paid even if an individual submits the letter of objection.

R.1.15 Where a specific penalty is not fixed by these rules, regulations and bylaws for the violation of any of the provisions herein, the Board of Directors, upon conviction of any member for the violation thereof, may impose a fine.

R.2.0 TIMED EVENT RULES

R.2.1.0 BARRIERS AND SCORELINE

R.2.1 The barrier judge is responsible to change barrier string whenever it may have been weakened, or on request of next contestant. Barrier judge shall keep a record of the length of the barrier trip rope each performance to assure the same start for contestants each performance. Adjusting length of barrier trip rope will be accomplished only by tying

knots in the rope on either end. A 10-second penalty will be added for breaking or beating the barrier. Broken barriers will be recorded by barrier judge and turned in with their books to the rodeo secretary.

R.2.1.1 If, in the judge's opinion, the barrier fails to work properly (malfunction), the judges will make the decision on breaking the barrier or getting out. Judges' decision to be made immediately and decision final.

R.2.1.2 If the barrier pulls early and the contestant declares without pursuit, the contestant will receive animal back.

R.2.1.3 If barrier flag man is used, animal is to be flagged when crossing starting, or deadline, in front of flag with same. Slide will be used on automatic barrier neck ropes.

R.2.1.4 Once score line has been set in timed events it will not be changed at the rodeo, nor can length of box be changed.

R.2.1.5 If in the judge's opinion contestant is fouled by barrier and/or neck rope the contestant must declare immediately. Any penalties incurred before the foul will be assessed. If broken barrier is assessed, animal will be given back lap and tap plus 10 seconds. (Judge needs to be aware of the difference between a foul and a malfunction at/of the barrier).

R.2.1.6 In order for time to be considered official, barrier flag must operate.

R.2.2 If time has been called for and catch or run is considered illegal, it will be considered a No Time.

R.2.3 All changes in lists or roping order to split horses, etc., must be made before any stock for

that event is loaded in chutes. After stock is loaded, ropers must rope in order listed.

R.2.4 There shall be two or more timers, a field flag judge and a barrier judge, time to be taken between two flags.

R.2.5 Field Flagger: Judges flagging an event must position themselves whenever possible:

In the breakaway roping - three fourths of the way down the arena from the RIGHT hand side of the arena as viewed from the box, unless arena conditions dictate otherwise, so as not to interfere with the running of the cattle..

R.2.6 In any timed event if an animal escapes from the arena, flag will be dropped and watches stopped. Contestants will get animal back with lap and tap start, and time already spent will be added to time used in qualifying. If time is not recorded, the decision of the flag judge shall be final.

R.2.6.1 If a rope is on animal, roper will get animal lap and tap with rope on it in the chute.

R.2.7 The decisions of any judges, flagmen or timers will be final and no protests by contestants will be permitted.

R.2.8 No contestant may talk to a judge or timer in any way while an event is going on. Questions may be addressed to the judge no sooner that at the end of the event for that performance. Any contestant violating this regulation will be reported to the Association office by the judges or the arena director or stock contractor of the rodeo where the violation occurs. Violators will be fined \$50.00.

R.2.9 A barrier judge is allowed to compete in the timed events if he finds some responsible

member to watch the line in that event for the day he is competing.

R.2.10 If an animal in timed events escapes the chutes or pens before it is called for by a contestant or another contestant competes on the wrong animal that same animal will be brought back for the contestant to compete on. The animal will be returned by the arena director and the labor crew during, or at the end of that performance or slack in the same manner he was originally worked or brought to the pens for contesting. At least 3 head of animals will be brought back together. No animal may be re-penned by himself. Decision will be made by arena director about when stock is re-penned.

R.2.11 Cattle may be lined only to the scoreline.

R.2.12.0 BARRIER

R.2.12 Non-Competing Horses in Box. Only horses being used in a competitive run during an event will be allowed in the boxes during any timed event and/or noncompetitive runs. Each offender shall be subject to a \$25.00 fine for the first offense, and the fine shall double with subsequent offense.

R.2.12.1 Scoreline (not neck rope) will be set as follows: (Minimum) Length of box minus 4 feet
- Governed by type of cattle roped.

R.2.12.2 Scoreline will be set according to arena and box length and conditions, but when conditions warrant, the score shall be set as stated above. Event director shall have final approval of scoreline length.

R.2.12.3 A tape measure is an absolute necessity for any barrier judge.

See Figures 1 and 2 for set up of barrier.

FIGURE 1

When measuring score where barrier rope pulls from side of chute or under 5' high with a top pull length of barrier rope, with neck rope attached, shall be 24 inches behind score line in steer wrestling and team roping and 18 inches behind score line in calf roping.

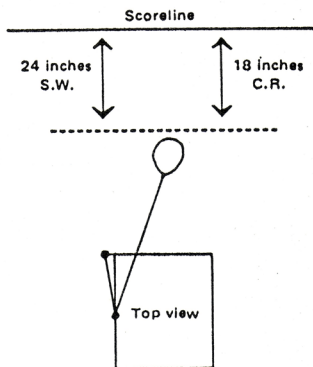
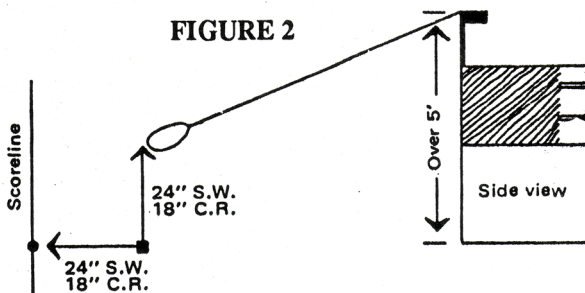

FIGURE 2



When measuring the length of barrier rope when rope pulls from the top of the chute — this would be any time rope pulls from 5 feet high on the chute or over — judge should make sure flag is up and pin in place. End of barrier rope, with neck rope attached, should come to a point 24 inches behind score line and 24 inches "up" from the ground in steer wrestling and team roping. It shall be measured 18 inches behind and 18 inches "up" in calf roping. Barrier string height should be 32 to 36 inches high, measured in the center.

R.2.12.4 Prior to the first performance, check to see that all barrier equipment (pulleys, rings, ropes, etc.) are present on the barrier and in good condition. It is a good practice to carry all the necessary materials so that a new barrier can be built if necessary.

R.2.12.5 Barrier equipment must be inspected before each timed event. If equipment is faulty, it must be replaced. Should barrier break at any point other than the designated breaking point, contestant must take stock over.

R.2.12.6 Prior to each performance measure rope length to scoreline with pin in place. Measure from front of chute gate to end of neck rope and make sure this given length is maintained throughout the entire rodeo. All barrier measurements should be written in judge's book and turned in to the secretary. Barrier and gate should be put into operation and tested once or twice to see that everything is in proper working order. Barrier string (where rings are attached) should be checked prior to first contestant and each run thereafter. Make sure there is an ample supply of string. Replace string regularly since it may become frayed or worn. All broken barriers should be recorded in judge's book even though the stock may be missed.

R.2.12.7 Slide will be used on automatic barrier neck ropes.

R.2.12.8 In all timed events where a neckrope is used, string shall be the only material used to tie neck rope.

R.2.12.9 Automatic barrier must be used at all rodeos for breakaway roping. At indoor rodeos length of score may be no longer than length of roping box minus four feet unless other arrangements are approved by the ladies breaking roping director or representative.

R.2.12.10 Barrier equipment must be inspected by the judge before each timed event. if

equipment is faulty, it must be replaced. Should barrier break at any point other than designated breaking point, decision is up to the barrier judge. If contestant obviously beats barrier, or barrier rope is broken and string unbroken, barrier judge may assess a 10-second fine.

R.2.12.11 In order for time to be considered official, barrier flag must operate. The barrier flag should be on the barrier pole or barrier instead of on the neck rope of the timed event cattle whenever possible.

R.2.12.12 If neck rope fails to work, but time is recorded, contestant or team will get time. Barrier penalty will be waived unless obviously beaten by contestant.

R.2.12.13 If in the opinion of the line judge a contestant is fouled by barrier and/or neck rope the contestant shall get their calf or steer back providing contestant declares immediately.

R.2.13.0 DRAWING TIMED EVENT STOCK

R.2.13.1 Stock in timed events shall be drawn by either judge of that event, not more than two (2) hours before the performance or slack in the presence of the rodeo secretary.

R.2.13.2 Except for split performances, when one run ends and another starts during a performance, all cattle must be run once before any are run a second time. Second run of cattle must be completed before any are run a third time, etc. Thus all cattle will be run consecutively. There will be no consecutive runs on timed event stock unless an event is all that remains of slack.

R.2.13.3 A stock contractor must provide healthy and usable cattle which will be not less than 1/3 the number of entries for that event. If 1/3 the number of entries is a fraction, the contractor shall provide the next full number of cattle. In any event the minimum number of cattle shall be the number of entries in each event in the largest performance plus one. Event director shall have the right to change the number of cattle required.

R.2.13.3.1 In the event of short stock, the contractor will be fined by the NWRA as follows: first offense, \$50 per animal short; second offense, \$100 per animal short; third offense, \$200 per animal short and denied participation in NWRA Finals until all fines are paid in full.

R.2.13.4 Timed event cattle must be numbered with ear tags or iron numbers, and must be drawn.

R.2.13.5 One extra animal in each timed event will be drawn for all paid performances to be used in place of any animal drawn for that performance, but deemed unusable or misdrawn. The extra will be drawn from the animals remaining to be drawn after the performance has been drawn. If the extra is not used, it will be included in the next draw and not be considered run. The extra is not to be “issued” from the first draw to the first contestant in the next draw, but to be put back in draw and redrawn. Any additional misdraws will be done using standard misdraw procedures.

R.2.13.6 Once an animal is taken out of the draw he may not be returned to the draw for the duration of that rodeo.

R.2.13.7 Animals for all events will be

inspected before the draw, and no sore, lame, sick, or injured animal, or animals with defective eyesight shall be permitted in the draw at any time. Should an animal become sick or be injured between the time it is drawn and the time it is scheduled to be used in competition, that animal shall not be used in competition and another animal shall be drawn for the contestant, using misdraw procedures.

R.2.13.8 Timed event cattle shall be drawn as follows for short-go rodeos: (1) Timed event cattle for final go-round. All timed event cattle competed on at a rodeo by finalists will be used when drawing for final head. (2) Shortage of cattle for short go-round. If not enough cattle are available for a short-go round after using all the cattle brought in by the finalists, those remaining in the herd with the fastest times will be used. (3) Draw for finals or short-go. In a finals or short go-round, draw will be made from last position to first position. Also, events should be run accordingly.

R.2.13.9 Timed event cattle may not be moved from one event to another without the approval of both directors.

R.2.13.10 In case of a Misdraw discovered prior to a performance, or any time during the slack:

A) If one or more Extras are available, all animals not competed on below the Misdraw up to the end of the run on the cattle shall be eligible to be drawn. One animal is drawn, that being the animal assigned to the contestant with the Misdraw. The contestant who originally had that animal will be assigned the Extra. All other contestants will be assigned the animals originally drawn for them.

B) If no Extras are available, all unused animals below the Misdraw up to the end of the run on the cattle shall be eligible to be drawn, with the last unused animal drawn in that run designated the Extra.

R.3.0 LADIES BREAKAWAY ROPING RULES

R.3.1 There will be a twenty (20) second time limit with the gate closed. There is no time limit at the finals or at any place where there is more than one head of stock

R.3.2 There will be no reruns unless there is a barrier malfunction or flagging error.

R.3.3 Contestants will rope uniform muley cattle. The weight limit on muley cattle is a maximum of 400 lbs.

R.3.4 When roping muley cattle, the rope must pass over the animal's head and come tight on the legal area (behind the ears, in front of front hooves, and in front of tail head) and break away. Catching legs or a tail in the loop will be considered an illegal catch.

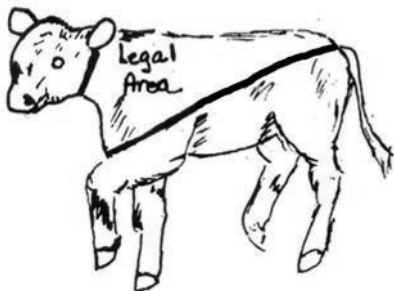

R.3.5 One loop only will be carried in the ladies breakaway roping event. One loop will be used during the NRA/NWRA Finals and any other average rodeos. A dropped loop is considered a thrown loop.

R.3.6 Ropes must be tied to the saddle horn with nylon string to be supplied by contestants OR provided by the judges. Ropes must have a colorful cloth attached to them, no more than 6 inches from the horn. String must be broken by the animal or a No Time assessed.

R.3.7 The judge will flag the contestant when the rope breaks away from the horn and time will be taken.

R.3.8 The contestant will receive a no time should she break the rope away from the saddle horn by hand. However, if the rope should dally around the horn, the contestant may ride forward, un-dally the rope, and then stop her horse to make the rope break away.

R.3.9 Anything not covered by the above rules will be covered by the men's tie-down roping rules.

R.3.10 All rodeos will have a "spotter" designated by the judges for the Ladies Breakaway Roping. The "spotter" should be on the opposite side of the arena from the flagger.

R.3.11 DELETED

R.4.0 LADIES CLOVERLEAF BARREL RACING RULES

R.4.1 The starting and finish line and the position for the barrels must be marked permanently for the entire rodeo. The contestant is allowed a running start. Time shall begin as soon as the horse's nose reaches the starting line and will be stopped when the horse's nose reaches the finish line. The starting and finish line are the same. Brightly colored 55-gallon drums shall be used with both ends intact.

R.4.2 It shall be the responsibility of the flag judge to ensure that the timers are ready before allowing contestant to compete.

R.4.3 At a signal from the flag judge, the contestant will run to barrel number 1, pass to the left of it and complete an approximately 360-degree turn around it; then go to barrel number 2, pass to the right of it, and complete a slightly more than 360-degree turn around it; then go to barrel number 3, pass to the right of it, and do another approximately 360-degree turn around it; and then sprint to the finish line between barrels 1 and 2.

CLOVERLEAF BARREL RACE PATTERN

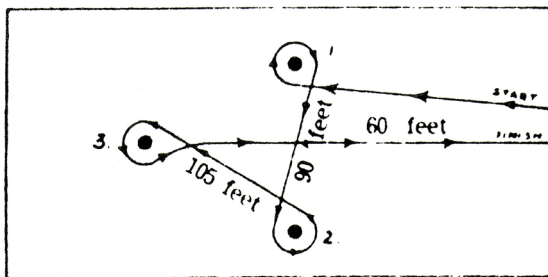

R.4.4 This barrel course may also be run to the left. For example, the contestant will start to barrel number 2, turning to the left around this barrel, then to barrel number 1, turning to the right, and then to barrel number 3, turning again to the right, followed by the final sprint to the finish line between barrels 1 and 2.

R.4.5 Contestants will be assessed a five-second penalty for knocking over a barrel.

R.4.6 Contestants will be disqualified for not following pattern, or not being ready to contest when name is called. Touching barrel is permitted.

R.4.7 Should barrel be knocked over and it sets up on opposite end, the five-second penalty will be assessed. Barrel must be set back on mark.

R.4.8 Two or more contestants are allowed to ride the same horse during the same go-around or finals.

R.4.9 If horse falls or similar incident occurs, the contestant cannot have a re-run.

R.4.10 A re-run is permitted if someone or some animal interferes with the run. Re-runs to be approved by a director or representative and flag judge.

R.4.11 All contestants shall enter the arena through one gate designated by the judge prior to the barrel race. Any contestant entering the arena through any other gate other than the one designated by the judge will be disqualified.

R.4.12 In slack, ground throughout the barrel pattern must be worked (not raked) conditions permitting, immediately before and after the barrel race and after the equivalent number of contestants drawn for the largest performance.

4.4.12.1 In a performance ground throughout the barrel pattern must be worked (not raked) conditions permitting, immediately after the barrel race.

R.4.13 The field flagger must remain in the same location for the duration of the barrel race for the entire rodeo. The judge who is not flagging is responsible for re-setting tipped over barrels.

R.4.14 The barrels will always be raked

between the Ladies Barrel Racing Event and the Junior Barrel Racing Event. Each rodeo committee is responsible for providing rakes and personnel to rake the barrels.

R.4.15 \$2 will be collected from every barrel racing contestant at each rodeo for the electric eye. If the electric eye fails to work and hand times are used, the \$2 is to go into an electric eye fund, to be used towards replacement or repair of the electric eyes.

R.4.16 Ladies Barrel Racing even will be run before the junior barrel racing event at all rodeos and slack.

R.4.17 If the electric eye malfunctions and the rodeo is paid off in hand times, times used for payoff to be tenths.

R.4.18 If the rodeo has additional events requiring the use of a barrel, barrels must not be put on NRA barrel markers.

R.4.19 Horses shall not be worked around the official pattern with or without barrels. Barrels shall not be set less than 15 feet off the markers. \$100.00 fine for first offense.

R.4.20 All contestants should run with a closed gate.

R.4.21 There will be no circling horses in the arena. One spin or pivot in either direction is acceptable if gate is not centered with pattern. When contestants are not required to run in and out, they must keep forward motion toward first barrel, prior to crossing score line. Violators to be reported by judge and \$25 fine imposed.

R.4.22 After gate is open and judge calls you into arena, you have one (1) minute to get your horse

in the arena without using excessive force. If you are unable to do so, it will result in a no time. There is to be only one contestant horse in the arena during the barrel race. If you have another horse or person on foot accompanying you to the arena, they may not enter the arena with you.

R.5.0 METHOD FOR MARKING BARRELS

R.5.1 Dig a hole approximately 1-1/2 feet deep, depending on the type of ground. Place the end of the rope that has several knots tied in the end (or that has a can or spike fastened to the end of it) in the hole. Tamp the dirt in securely around it, leaving about one foot of rope out of the ground. The barrels will be set on the inside edge of the pattern of the stakes, with the outside edge of the barrel on the stakes, as shown by diagram 2.



BARREL MARKER — DIAGRAM 2

R.5.2 The markers should be buried at the location of each barrel. By using this method the barrels will be in the same place during the entire rodeo. The starting line shall also be marked with permanent markers.

R.5.3 Judges are responsible for making sure pattern is set according to NWRA Rule Book prior to first performance.

R.5.4 The starting line must also be correctly measured back from barrel 1 and barrel 2, so the distance is the same to ensure barrel racers going either

to the right or left the same opportunity. Permanent markers shall be placed on both sides to indicate the starting line. All measurements must be turned in to the rodeo secretary before the first performance.

R.5.5 Prior to each performance the barrier judge is responsible to check barrel markings and scoreline.

R.5.6 Should for any reason the barrels not be placed on the marks or the flagman not be in the correct place, things must be put in correct order and all contestants who ran on the incorrect course must be rerun with no penalty.

R.5.7 Judge must make decision that barrels were not on marker. Should this happen, contestants and judges should be notified, then judge and arena director will set the time for rerun.

R.5.8 Should the marker be gone and a tape measure be used to set up the barrel pattern, that is sufficient, and no rerun will be allowed.

R.5.9 Standard courses should be used wherever possible. The standard distances for Cloverleaf Barrel Race are:

- a. 90 feet between barrel 1 and 2.
- b. 105 feet between barrel 1 and 3 and between 2 and 3.
- c. 60 feet from barrels 1 and 2 to scoreline. Scoreline should be 30 to 45 feet away from the fence.

R.5.10 The following shall be used in smaller arenas:

- a. The scoreline should be 30 to 45 feet away from the fence.
- b. Barrels 1 & 2 must be 18 feet from

the sides of the arena.

c. Barrel 3 must be 30 feet from the back of the arena, but may not be over 105 feet between barrel 1 and 3, or 2 and 3. Ninety feet between barrels 1 and 2 is the farthest they may be apart.

R.6.0 ELECTRIC EYE TIMER

R.6.1 Equipment necessary: Complete electric eye timer plus two stop watches to be operated manually. Complete electric timer must be backed up by a flag judge who will stand directly behind one timer post in the arena. Timers will record the times that appear on the electric-eye controlled readout disregarding the thousandth and recording the times in hundredths. Timers will also record the average time from the hand-held stopwatches in hundredths, in the place so designated on the timers sheet. Timers will also record the times from the stopwatches.

R.6.2 The timer posts in the arena will be placed on the permanently marked spots on the scoreline, a maximum distance of 140 (one hundred forty) feet apart. At no time will the electric eye be set inside the pattern of the first two barrels.

R.6.3 If an electric eye timer malfunctions for 51% of any one go-around, then flag times will be used for entire go-around. In the event the timer fails to work for an event and it is paid off on manual times, the timer charge collected will not be paid to the timer operator. It will be sent to the NWRA to be used for maintenance.

R.6.4 When the electric eye is used, both flag times and electric eye times will be kept in crow's nest, secretary's book and timers' sheet.

R.6.5 In the event the electric eye fails to operate; time from each of the two stop watches shall be averaged, and a zero will be added to the tenth (i.e. 17.1 becomes 17.10).

F.1.0 ANNUAL N.R.A. FINALS QUALIFICATIONS

F.1.1 The top ten money winners in NWRA events in the overall Association standing at the end of the regular season will be eligible to compete at the Finals rodeo. If any person in the top ten will be unable to compete, the numerical standings will be used to fill any positions.

F.1.2 In order to compete at the NWRA Finals rodeo, a contestant must have purchased a membership card and competed in that event at a Northern Rodeo Association approved rodeo the current Finals Rodeo Season.

F.1.3 A contestant who turns out of any or all of the performances of the NWRA Finals rodeo will be fined \$100 and denied eligibility at the following year's NWRA Finals.

F.2.0 FINALS PERSONNEL AND STOCK

F.2.1 Judges for the Finals will be provided by the NRA pursuant to the agreement between the NRA and the NWRA.

F.2.2 The timers, NWRA announcer, arena director, and secretary are selected by ballot and vote of the Board of Directors of the NRA and NWRA.

F.2.3 The arena director is responsible for the chute bosses and arena labor crew. Arena director will also be responsible for the care of timed event cattle used at the Finals rodeo.

F.2.4 Obtaining timed event cattle for the Finals rodeo will be the responsibility of the event director working in conjunction with the NRA.

F.2.5 Payment received by all Finals personnel will be based on contractual agreement with the NWRA and NRA.

F.2.6 Dates, location, selection of the production manager, are decided by the Board of Directors.

F.2.7 Ladies barrel racers will run in the 1st through 10th position for the first go; for the second and third go-rounds, the order of the event will be the contestant's finish prior go-rounds. For the ladies breakaway roping the first round order will be 10th place to 1st place. Second round order will be slowest time in first go to fastest time. Third round order will be 10th in the average to 1st in the average. There will be no trading of positions at the Finals Rodeo.

F.3.0 PAYOFF

F.3.1 The Finals rodeo will pay four monies per go-around, 40%, 30%, 20%, 10%, and an average of 1 1/2 times the go-around money.

F.3.2 The Finals purse will include: 3% of all rodeo season's collected prize money, all collected turn-outs and other fine monies, sponsorships as available, and other monies determined available by the Board of Directors and/or Advisory Board.

F.4.0 TIME LIMITS

F.4.1 There will be no time limits in any timed event during the Finals rodeo.

F.5.0 ENTRY CLOSING

F.5.1 NWRA Finals entries will be taken the Monday following Labor Day Weekend. Entries will be taken Monday & Tuesday from 10 – 5.

F.5.2 NWRA Finals entry fees must be paid at the NRA/NWRA Finals by the end of check in.

ANY CIRCUMSTANCES WHICH ARE NOT COVERED BY THE FOREGOING RULES SHALL BE GOVERNED BY THE WOMEN'S PROFESSIONAL RODEO ASSOCIATION (WPRA) RULES AND BY LOCAL GROUND RULES AS APPROPRIATE. THE ACTION OF THE BOARD OF DIRECTORS IN INTERPRETING THE RULES IS FINAL. IN ALL INSTANCES THE RULES WILL BE INTERPRETED SIMPLY AND WITH COMMON SENSE.